

VTA's BART Silicon Valley Extension Program



Joint VTA/BART Working Committee

August 26, 2022



Solutions that move you



Agenda

1. VTA's BART Phase II Project Update
 - a. Project Highlights
 - b. FTA Update
 - c. Innovations
2. Ongoing Collaboration Efforts
 - a. Operations Control Center (OCC)
 - b. Peer Review/Exchange
 - c. Recent & Upcoming Coordination

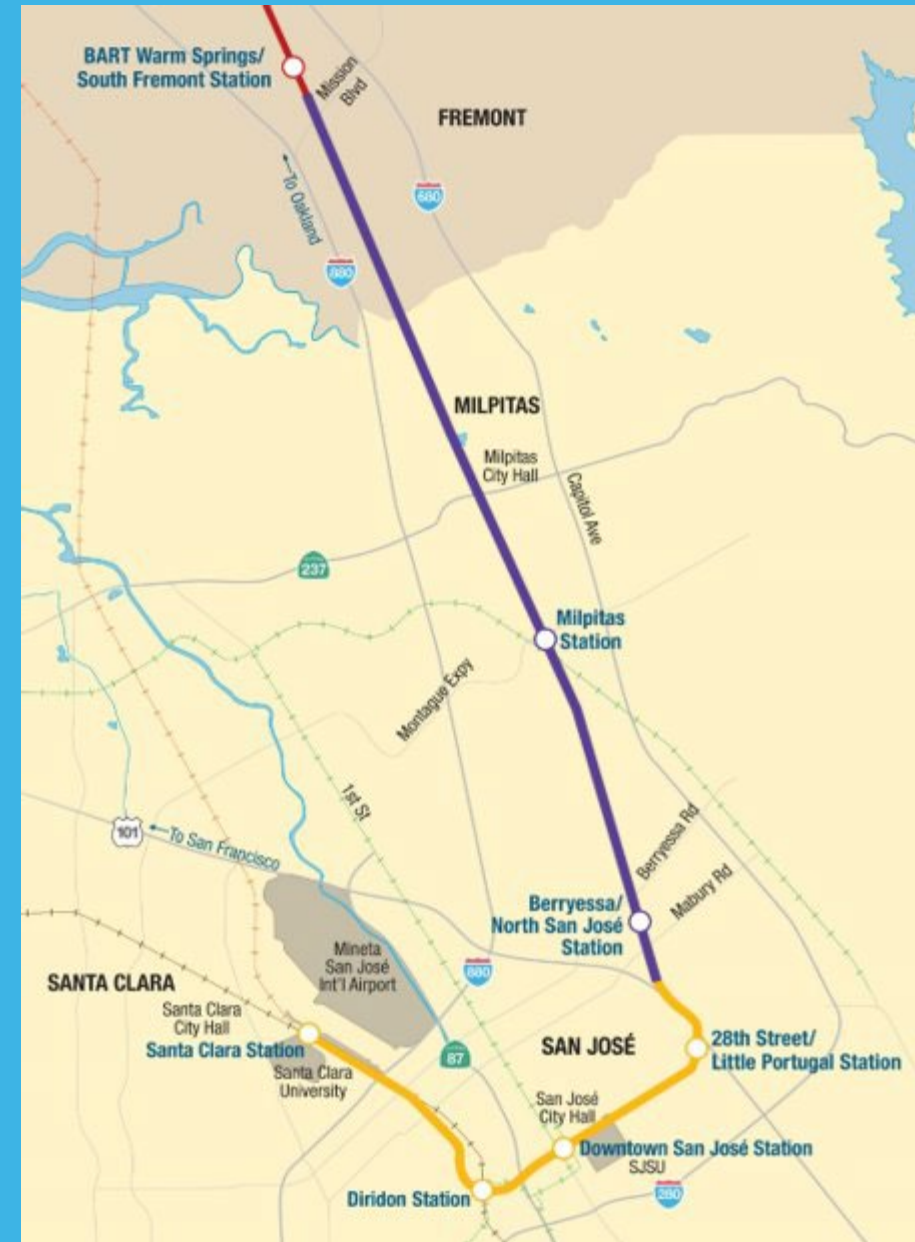

BART Silicon Valley Phase II (BSVII) Update

VTA's BART Silicon Valley Phase II (BSVII) Project Overview

- 6-Mile Extension:
 - ~5 mile single-bore tunnel
 - ~1 mile at-grade
- 4 Stations:
 - 3 underground
 - 1 at-grade
- Newhall Yard Maintenance Facility



Project Highlights

- Real estate acquisition process progressing with negotiations underway for key properties
- Second round of cooperative agreements with Cities of San Jose and Santa Clara being finalized and nearing execution
- Continued ongoing technical coordination with partner agencies and third-parties including Cities of San Jose, Santa Clara, JPB, and PG&E (including for TBM power)
- Stakeholder, community and business outreach continues along the corridor
 - VTA hosting a Community Social on August 27, 2022

Keep Informed on VTA's BART Silicon Valley Phase II Extension Project

BART SILICON VALLEY PHASE II EXTENSION PROJECT

Event: Community Social for VTA's BART Silicon Valley Phase II Project
Date: Saturday, August 27th
Time: 10:00 am to 2:00 pm
Location: Outside the VTA Downtown San José Customer Service Center, 55-A W Santa Clara St. San Jose, CA 95113

COME TALK WITH STAFF

FLY-THROUGH VIDEOS OF THE STATIONS

PHOTO-OPS

TUNNEL BORING MACHINE VIDEO

VTA invites you to learn more about the BART Silicon Valley Phase II Extension Project, ask questions, and provide feedback on various items at the Project's Community Social. The outdoor event is intended to be a celebration of the history, momentum, and upcoming construction of VTA's BSV Phase II Project. VTA looks forward to seeing you there!

Learn more about the project and sign up for updates at vta.org/bart

BART & VTA Recent Highlights

- **Design Criteria Manual:**
 - VTA and BART joint sign-off on Design Criteria Manuals (DCM) included in final procurement documents.
 - Jointly identifying required updates to the Design Criteria to align with advanced design documents and proposed CP2 innovations
- **Contract Package (CP) Documents:**
 - Supporting CP1 (Systems) ongoing technical work
 - Working together on CP2 (Tunnel/Track) innovation phase; co-located with selected Contractor
 - Continued refinement of CP3 (Newhall Yard/Santa Clara Station) yard design. Participating in 1:1 meetings with shortlisted teams.
 - Review of CP4 (Stations) contract package draft revision and supporting technical coordination with other CPs
- **Other Areas:**
 - Lead ongoing Safety and Security Certification progress meetings
 - Participating in station refinement workshops with SPUR / City of San Jose reviewing and exploring potential station enhancements for elements including vertical circulation, passenger experience/access and TOD integration

Fire Life Safety and Security (focus on code compliance)

- The Fire/Life Safety and Security Committee (FLSSC) has been established and continues to meet as required; The FLS Technical Working Group (TWG) membership includes the local Fire Departments and meets biweekly to review relevant FLS issues and develop suggested resolution options, with the goal of concurrence in support of the project.
- FLS design criteria sections have been reviewed by FLSSC. The FLS TWG is engaged during the CP2 innovations process reviewing proposed concepts
- The CPUC is satisfied with the partnership among VTA, BART and the local Fire Departments, and the FLSSC role in the Safety Certification process.

BART SILICON VALLEY PHASE II DESIGN CRITERIA CONFORMANCE CERTIFICATION Preliminary Engineering Certificate of Conformance	
Certifiable Factor: 1a	Contract: <u>CP2</u> Certifiable Element: <u>Guideway</u>
<p>In accordance with the requirements of the BSVII Safety and Security Certification Plan, I certify, to the best of my knowledge, that:</p> <ol style="list-style-type: none"> 1. The design contract documents incorporate safety and security criteria applicable to BSVII. 2. The design contract documents for this Contract incorporate applicable codes and standards, BART Facilities Standards requirements and Design Criteria Manual requirements. 3. Safety related design review comments for this Contract have been satisfactorily resolved. 	
<p>Exceptions --- Each exception and associated restrictions/workarounds must be explained. Restrictions/workarounds must be adequate so that the level of safety is not reduced. Use additional sheets if necessary</p>	
<p>DocuSigned by: <u>Dave Young</u> 9/16/2021 <small>8E2772F8D5A40D5</small></p> <p>Certified (Signature and Date) Dave Young, BSVII Engineering Lead, SVTC</p>	<p>DocuSigned by: <u>Anthony C Bauer</u> 9/14/2021 <small>88892C8A87C8530</small></p> <p>Certified (Signature and Date) Anthony Bauer, BSVII Engineering Manager, SVTC</p>
<p>DocuSigned by: <u>John Caulfield</u> 9/21/2021 <small>3492128870C8E24</small></p> <p>Concurred (Signature and Date) John Caulfield, BSVII Project Manager</p>	<p>DocuSigned by: <u>Takis Salpeas</u> 9/21/2021 <small>AD40607890904F4</small></p> <p>Accepted (Signature and Date) Takis Salpeas, Chief BART Delivery Officer</p>

Procurement Update

- Systems (Contract Package 1)
 - Additional rounds of one-on-ones ongoing
 - Final RFP tentatively to be issued this year, to allow for further interface coordination with CP2/3/4
- Tunnel & Trackwork (Contract Package 2)
 - Limited Notice to Proceed issued
 - Investigation of potential innovations underway including evaluation of cost/schedule savings
 - Task force meetings with VTA, BART and CP2 contractor to assess proposed innovations
- Newhall Yard/Santa Clara Station (Contract Package 3)
 - Additional round of one-on-one interviews held in July
 - Final RFP tentatively to be issued later late Summer
- Stations (Contract Package 4)
 - Development of technical documents continue in support of the other Contract Packages
 - Design coordination with third parties ongoing
 - Evaluation of alternative delivery methods and timing of procurement underway



FTA Funding Update

- Last October, VTA received a Letter of Intent (LOI) with pre-award authority from FTA under the Expedited Project Delivery (EPD) program
- VTA continues project activities with pre-award authority to incur costs for engineering activities, utility relocation, real estate acquisition, and other non-construction activities such as procurement of equipment.
- Monthly progress meetings with FTA continue discussing next steps to a Full Funding Grant Agreement (FFGA)
- VTA exploring alternative federal funding option with potential higher contribution



Conceptual Rendering – Subject to Change

Framework to Completion

This framework will be updated into a final project schedule based on completion of the procurement process.

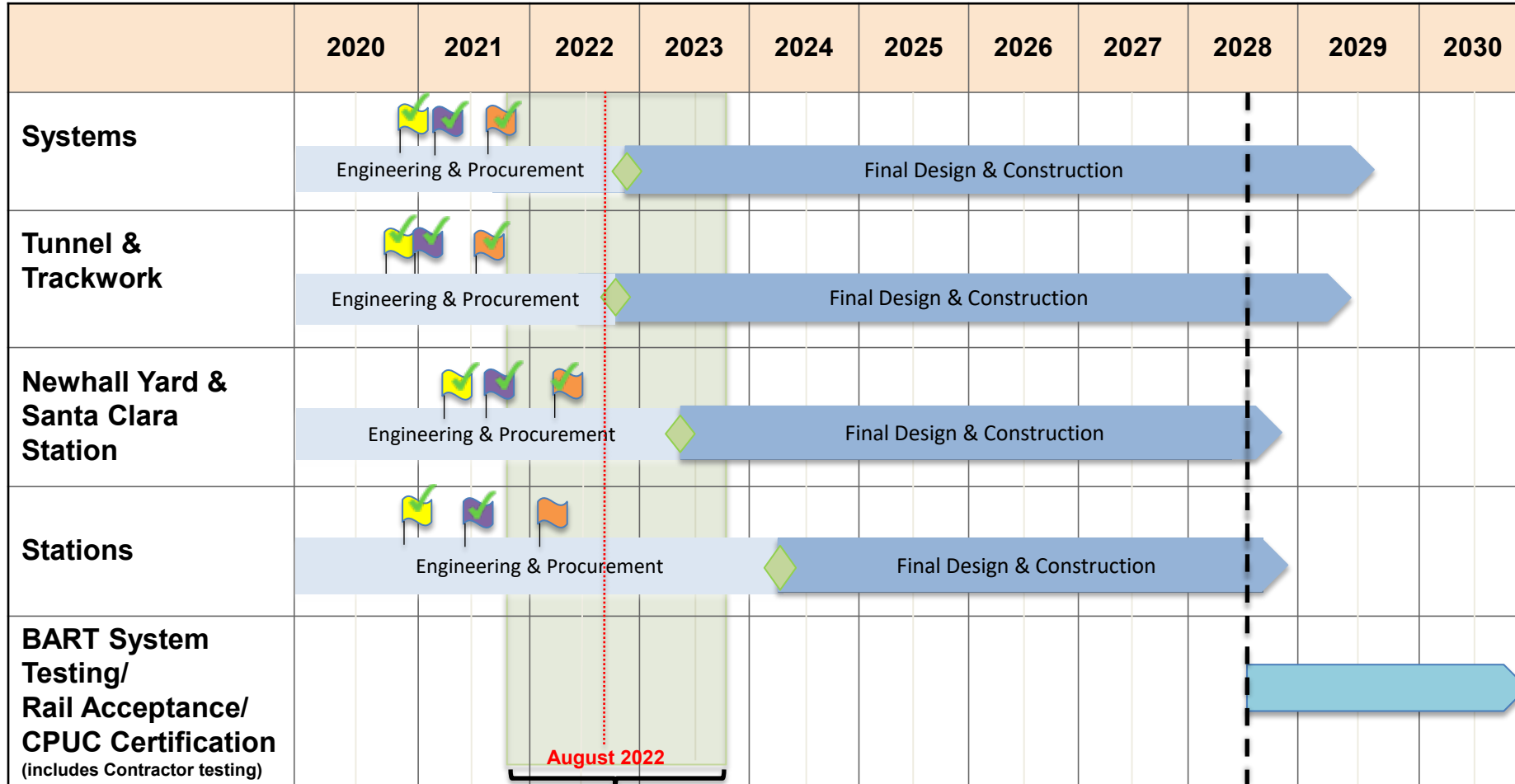

Framework subject to change based on industry feedback.

Two Year FTA LOI Window

Substantial Completion

Legend

- RFIF
- RFQ
- RFP (Draft)
- NTP

Proposed Innovations

Extract from Contract Package 2 (CP2) – Tunnel/Trackwork Request for Proposals:

C4.7 INCORPORATING INNOVATIVE / ALTERNATIVE SOLUTIONS

The Technical Submittal may include a summary outlining the specific areas where the Proposer has introduced innovation into the Proposal. Descriptions must include where innovations have provided enhanced quality in long-term performance, durability, maintainability, maintenance of traffic, sensitivity to aesthetic aspects of the Project, or other enhancements. For each innovation described, Proposer must include a separate estimate of cost impacts in sufficient detail to allow a thorough analysis with Form IP. Do not include the estimate with the description.

Innovation Phase: Goals & Criteria

1



Operations
Maintenance
Safety

2



Passenger Experience

3

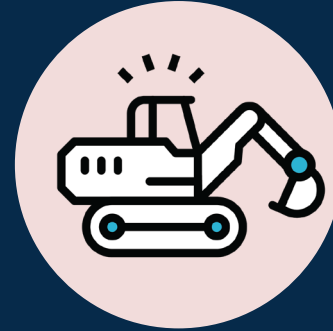

Constructability

4

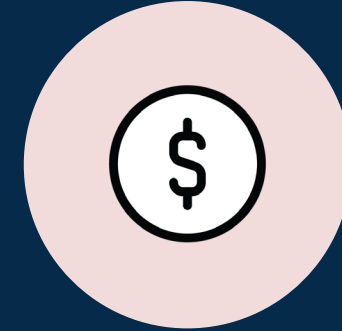

Improve Cost and
Schedule

Innovation Process

- 38 innovations initially developed and further consolidated into 16 innovations through a series of collaborative technical workshops with VTA, BART and CP2 Contractor (Kiewit Shea Traylor)
- Innovations/Optimizations were ranked into the following groupings:
 - High, Medium and Low Value and Retired
- Limited Notice to Proceed period issued with a 90-day Innovation Phase for further design development, evaluation and estimating of 16 innovations

Innovation Evaluation Process

Tier 1: Confirm No Fatal Flaws (Technical, Constructible, Acceptance, Identify Exceptions and Contract Modifications)

Tier 2: Refine Design to Support (Estimating, Schedule, Risk Matrix) Update ROM, Schedule and Risk Matrix

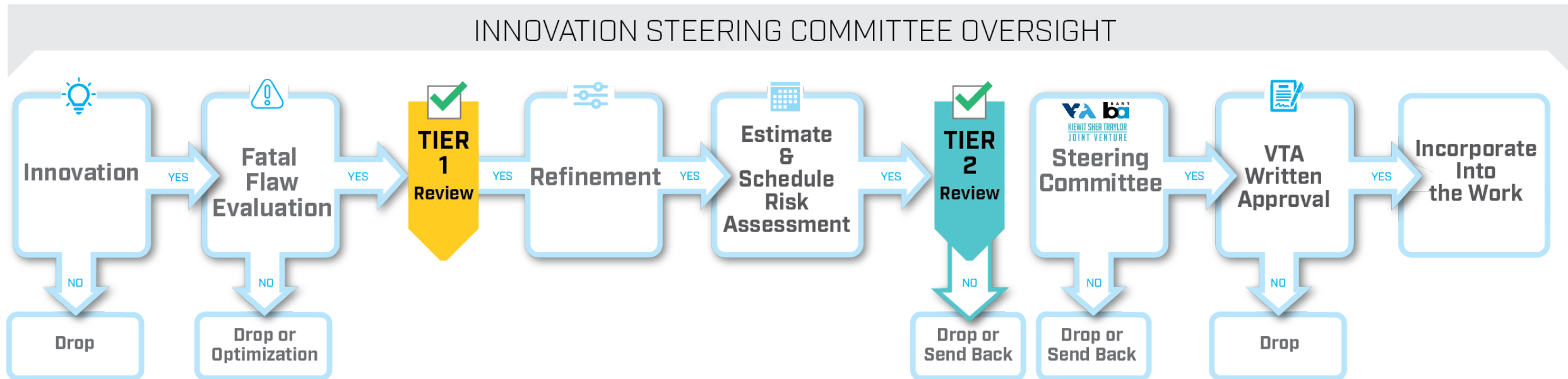

Innovations

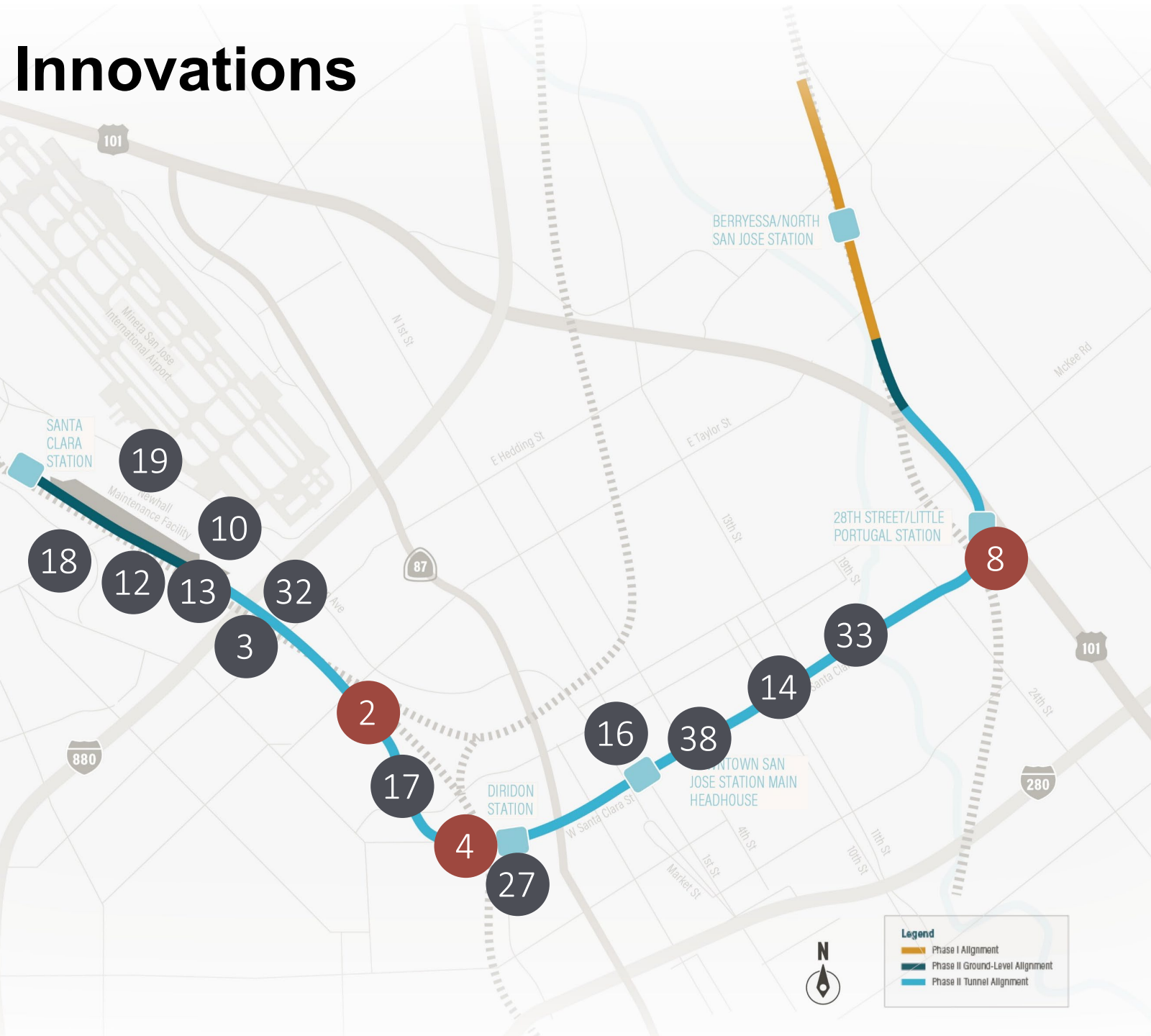

INNOVATIONS

2	Alternate Ventilation Configuration	
3	Interior Pre-Cast Track Slab	
4	Side-by-Side with Center Platform	
32	Maximize Interior Pre-Cast	
17	Steel Fiber Reinforced Concrete	
33	Tunnel Lining Fault Zone	
18	Newhall Casting Yard	
19	Redi-Mix Plant at Newhall Yard	
8	28th Street Station Bored Tunnel	
10	Confinement Wall Optimization	
12	Alternate Approach to TBM Break In and Break Out	
13	West Portal TBM Break Out	
14	Alternate Track Invert	
38	Trackwork - Reduce Interlockings	
16	Cast Iron Segments Optimization	
27	Adit Configuration	

LEGEND

- Improves Operations, Safety, & Maintenance
- Improves Passenger Experience
- Improves Cost & Schedule
- Improves Constructability

Key Innovations

- 4. Single Bore Tunnel w/ Side-by-Side Tracks & Center Platform
- 8. 28th Street/Little Portugal Station Reconfiguration
- 2. Ventilation Optimization



Single Bore: Side-by-Side Tracks w/ Center Platform

ORIGINAL DESIGN

~43' ID
~48'6" TBM

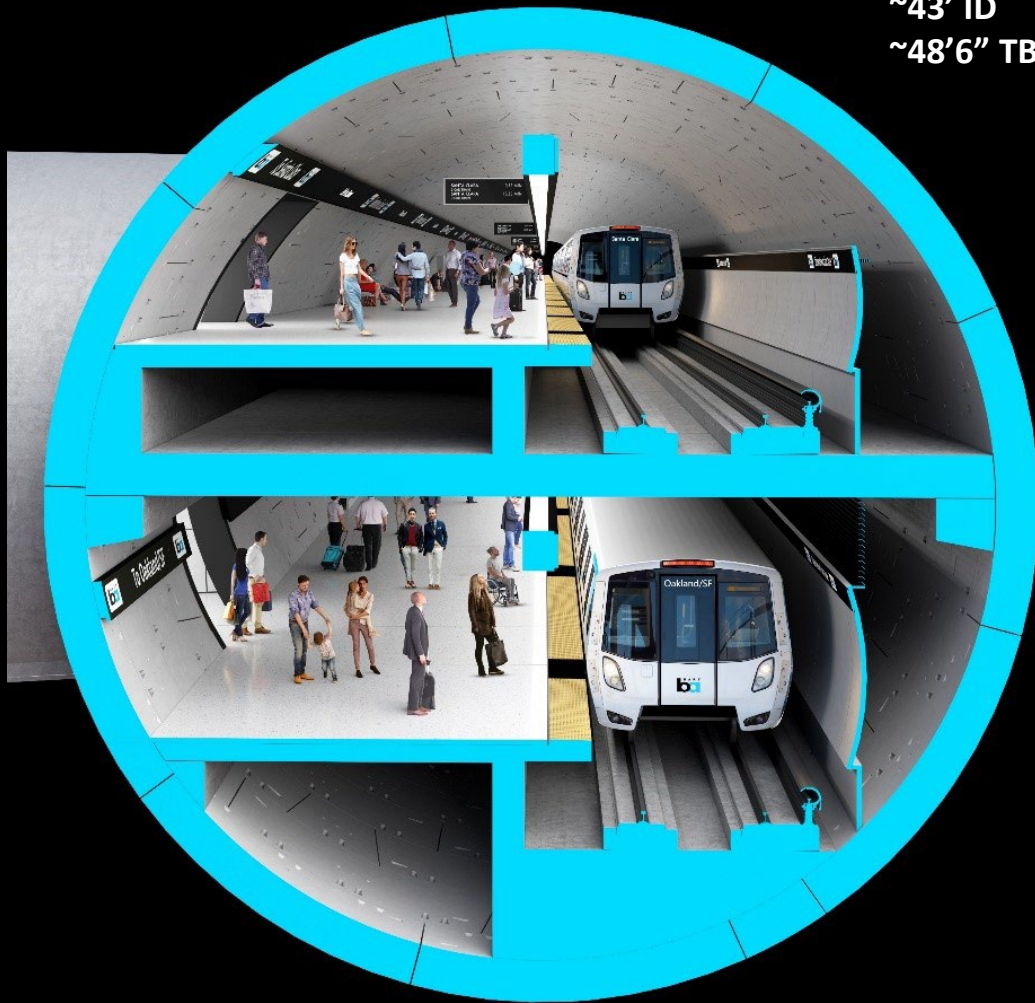

PROPOSED INNOVATION

~48' ID
~53'2" TBM

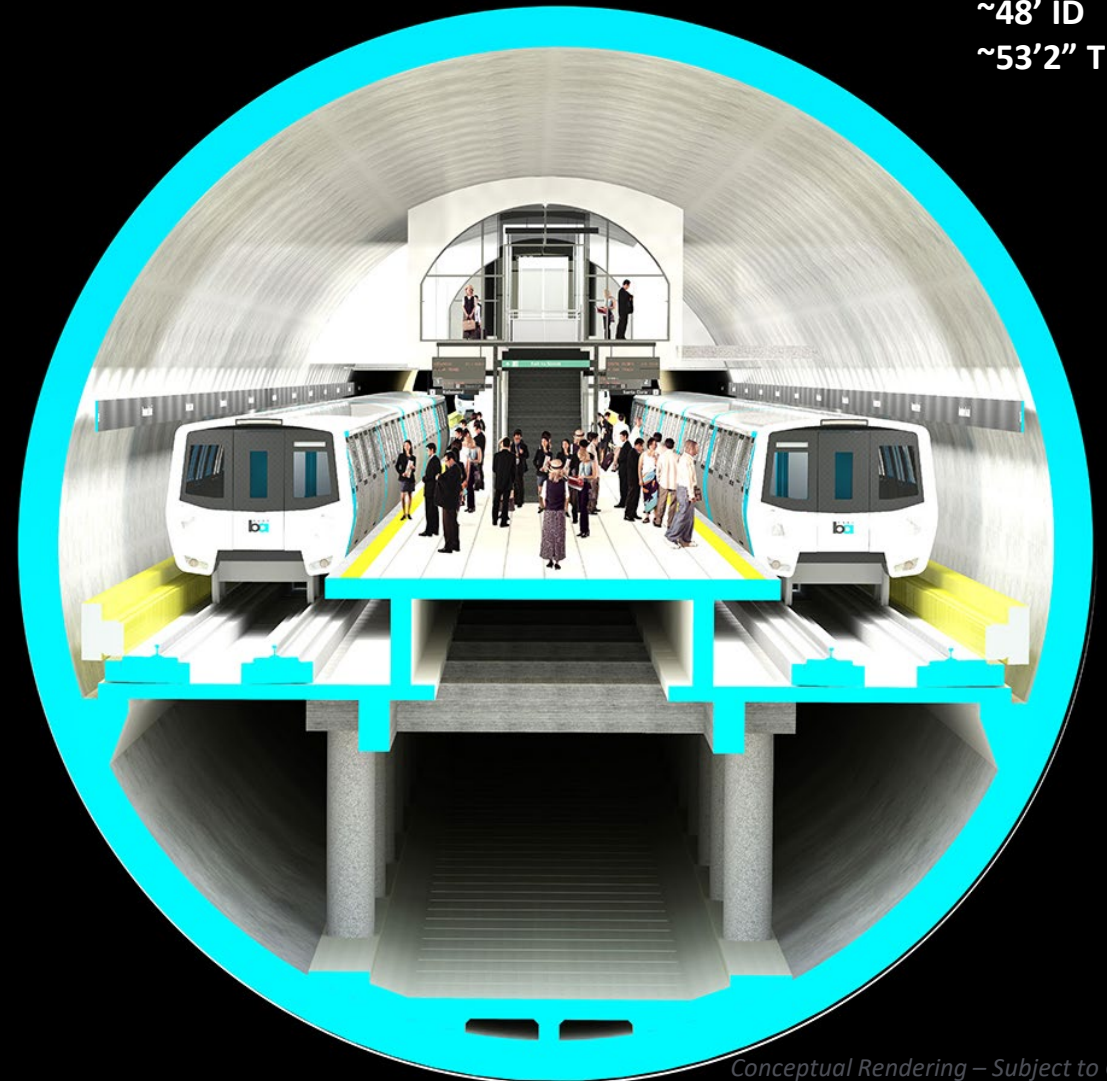

Single Bore: Side-by-Side Tracks w/ Center Platform

Solutions & Improvements:

- Operational flexibility – better cross over locations and opportunity for future access
- Passenger Experience is improved with
 - Standardized wayfinding
 - Simplified path of travel & reduced depth of station headhouses
 - Center platform and Mezzanine
 - More intuitive emergency egress and shorter distance to point of safety
- Improves construction schedule and sequencing
 - Reduces operations within interior buildout steps
- Optimizes size and location of adits

PROPOSED INNOVATION

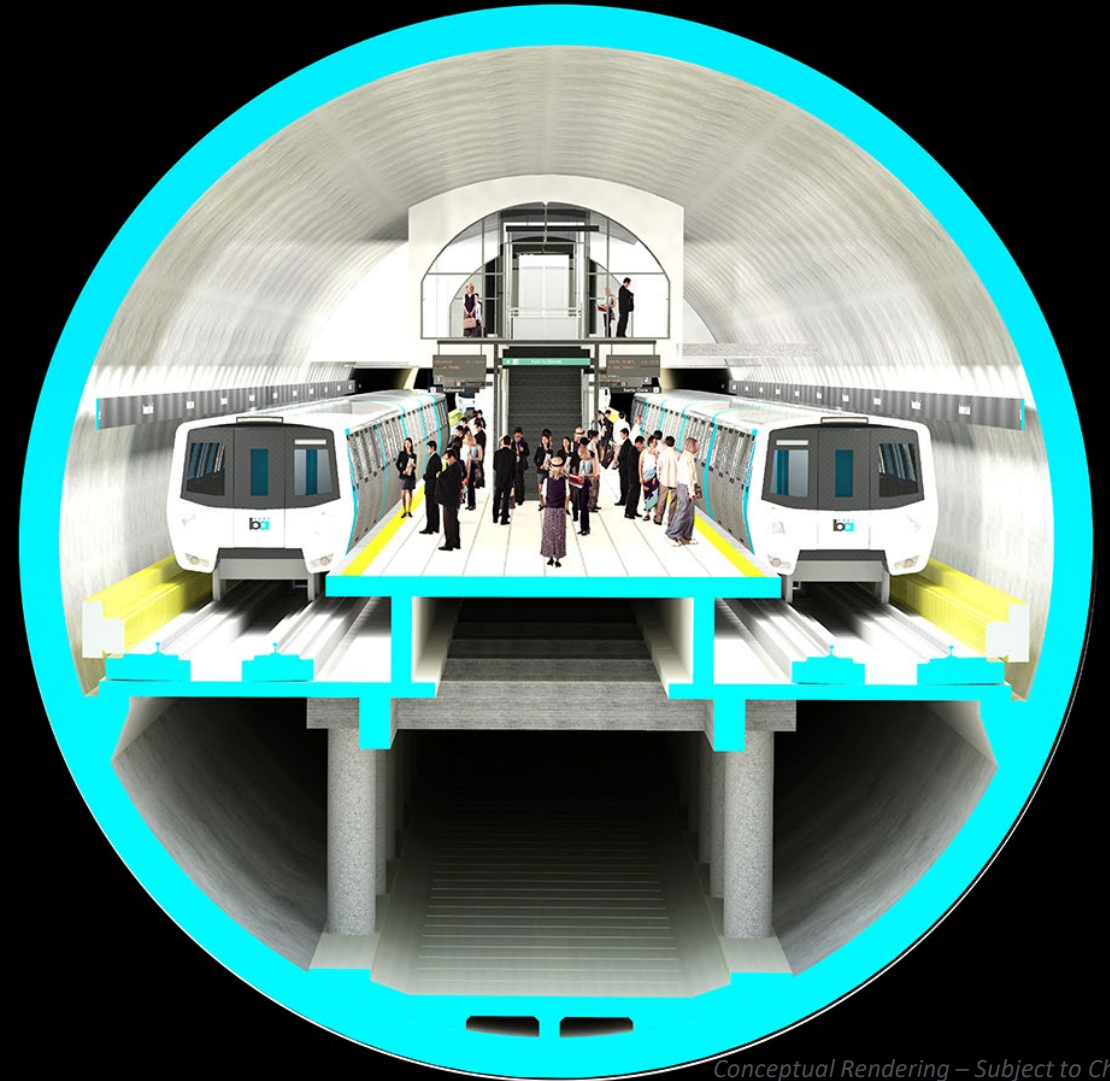

Downtown San Jose Station Layout

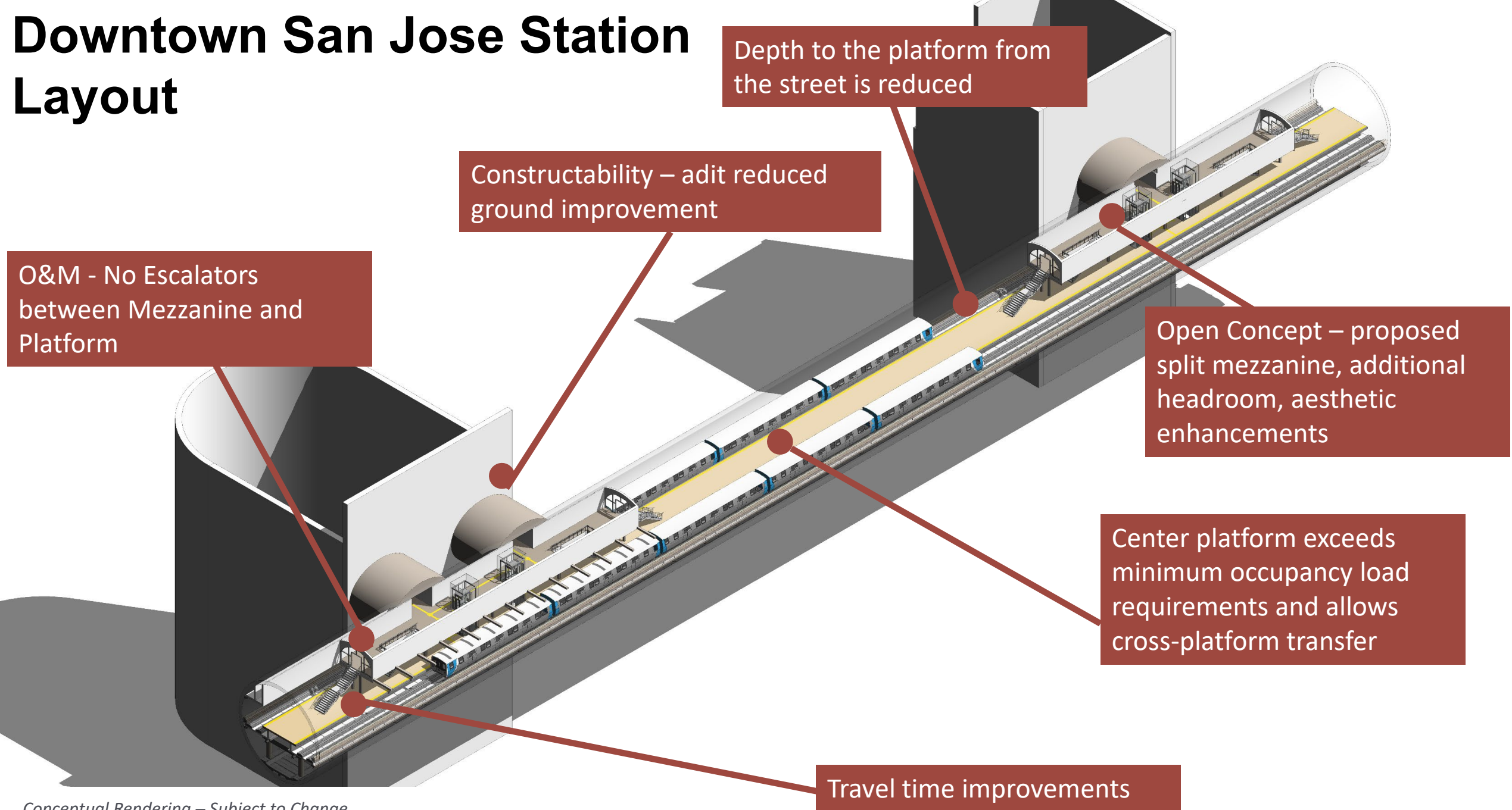

Depth to the platform from the street is reduced

Constructability – adit reduced ground improvement

O&M - No Escalators between Mezzanine and Platform

Open Concept – proposed split mezzanine, additional headroom, aesthetic enhancements

Center platform exceeds minimum occupancy load requirements and allows cross-platform transfer

Travel time improvements

Conceptual Rendering – Subject to Change

Future Station Access Opportunities

Additional Benefits

- During the mining of the tunnel, steel segments with “doors” can be added at future station access points
- With appropriate accommodations made at the mezzanine level, this provides flexibility for additional access as needs are identified.
- Allows for minimal impact to operations - offline shafts and horizontal adits

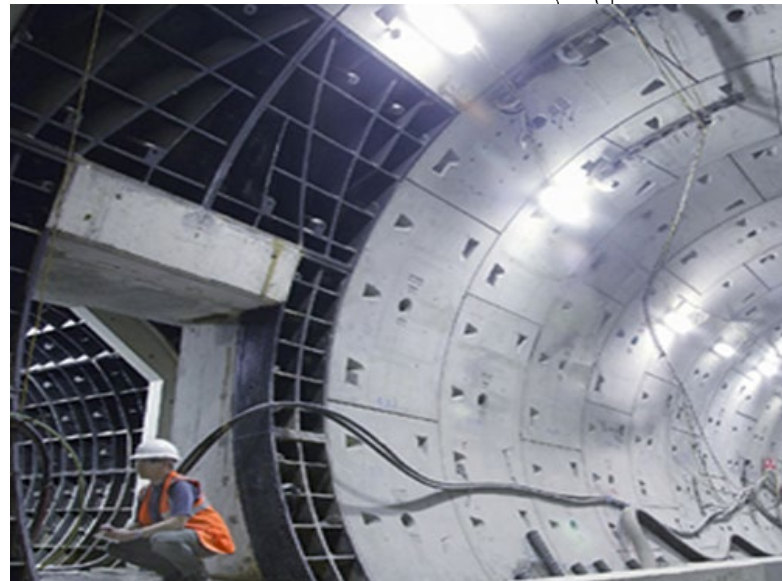
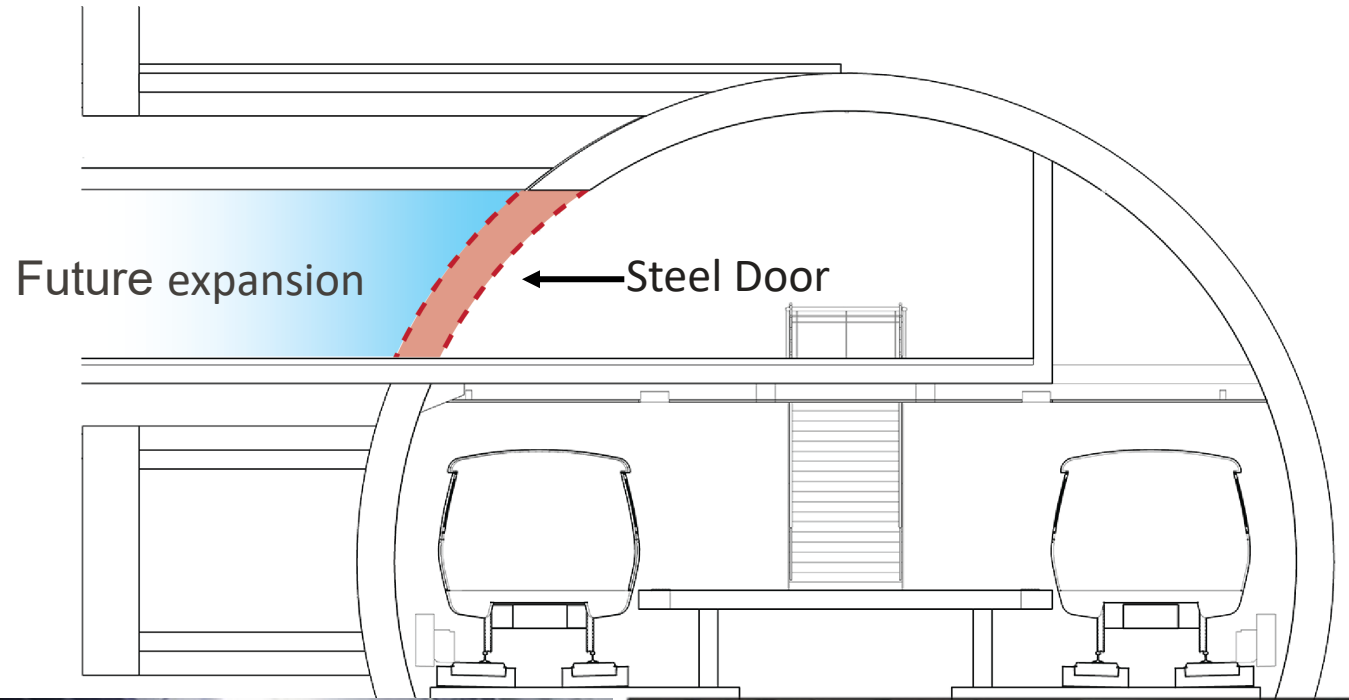

Single Bore Side-by-Side Tracks w/ Center Platform Summary

CRITERIA

↑ Improved = Neutral



OPERABILITY

- Side-by-side is more conventional from an operations standpoint and it improves headways over the Original Design



MAINTAINABILITY

- Simplified interior structures and trackwork leading to easier maintenance than Original Design



SAFETY

- Enhanced safety through consistent egress to non-incident tunnel. Simpler for emergency responders to address issues



PASSENGER EXPERIENCE

- Center platform and side-by-side configuration simplifies passenger experience compared to stacked station configuration



RISK

- Increased tunnel diameter, balanced by simplified interior build-out construction



COST

- Reduced cost compared to stacked configuration



SCHEDULE

- Allows for efficiencies in tunnel construction including interior build-out, which are challenged by stacked configuration during tunneling

28th Street/Little Portugal Station Reconfiguration

ORIGINAL DESIGN

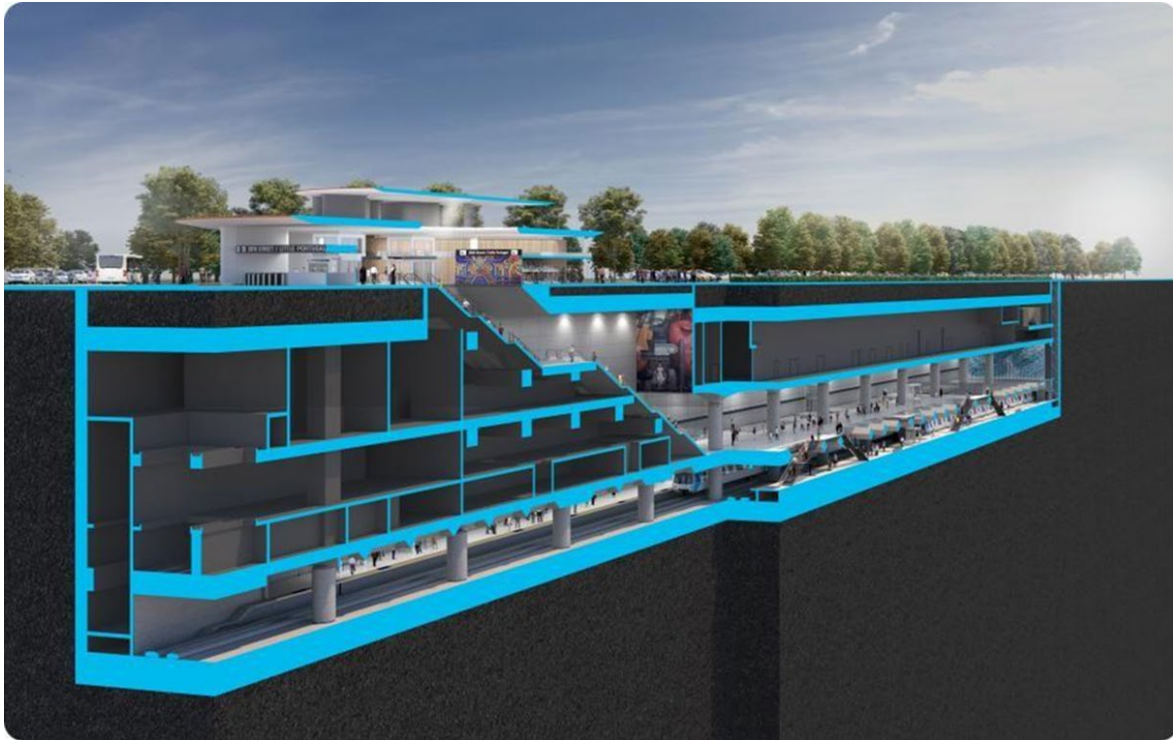

PROPOSED INNOVATION

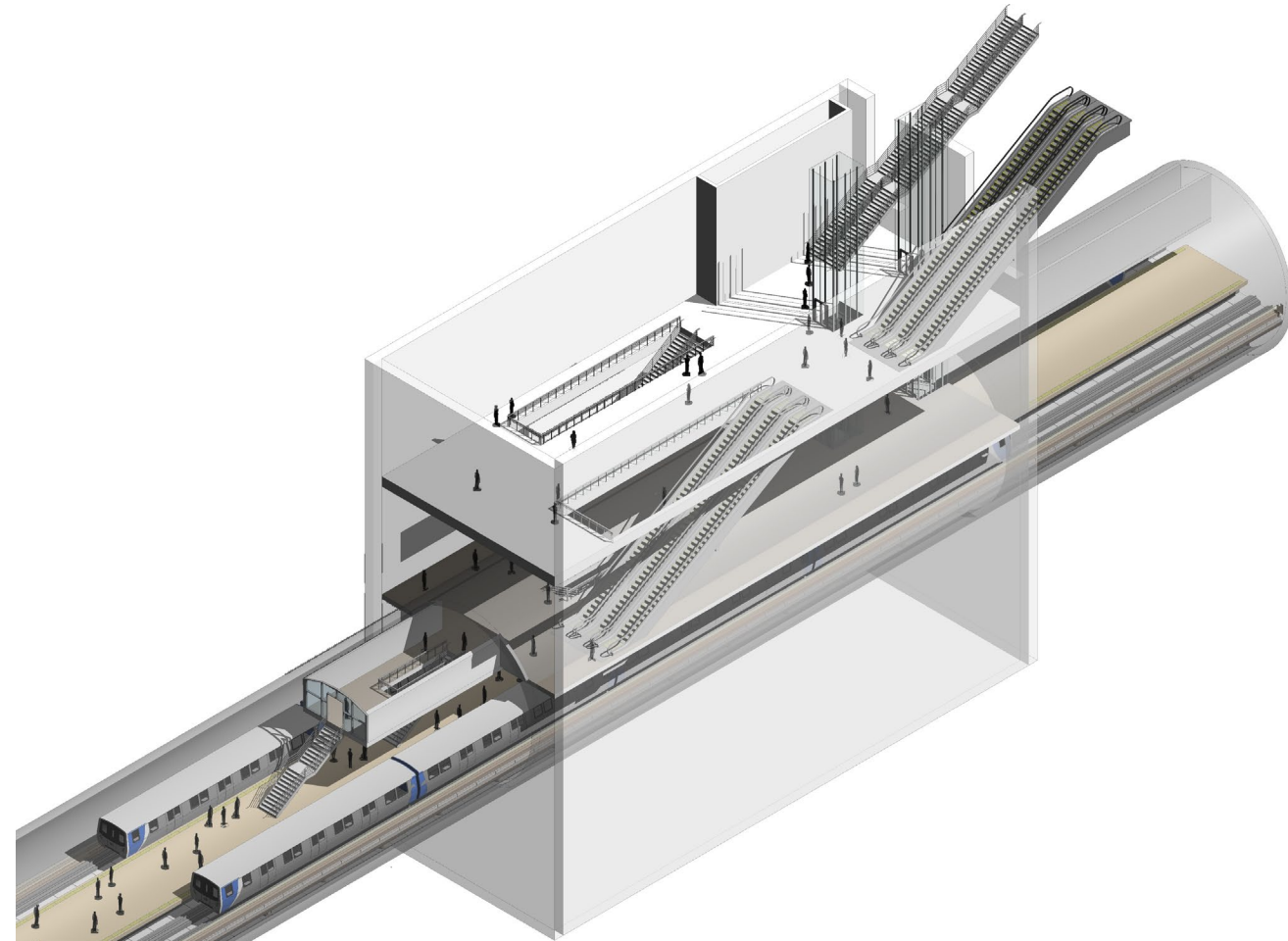

28th Street/Little Portugal Station Reconfiguration

Solutions & Improvements:

- Reduces surface disruptions
- Station platform and mezzanine built within tunnel, similar to Downtown San Jose and Diridon Stations
- Significant reduction in excavation volume
- Reduce interior concrete quantities with resultant savings

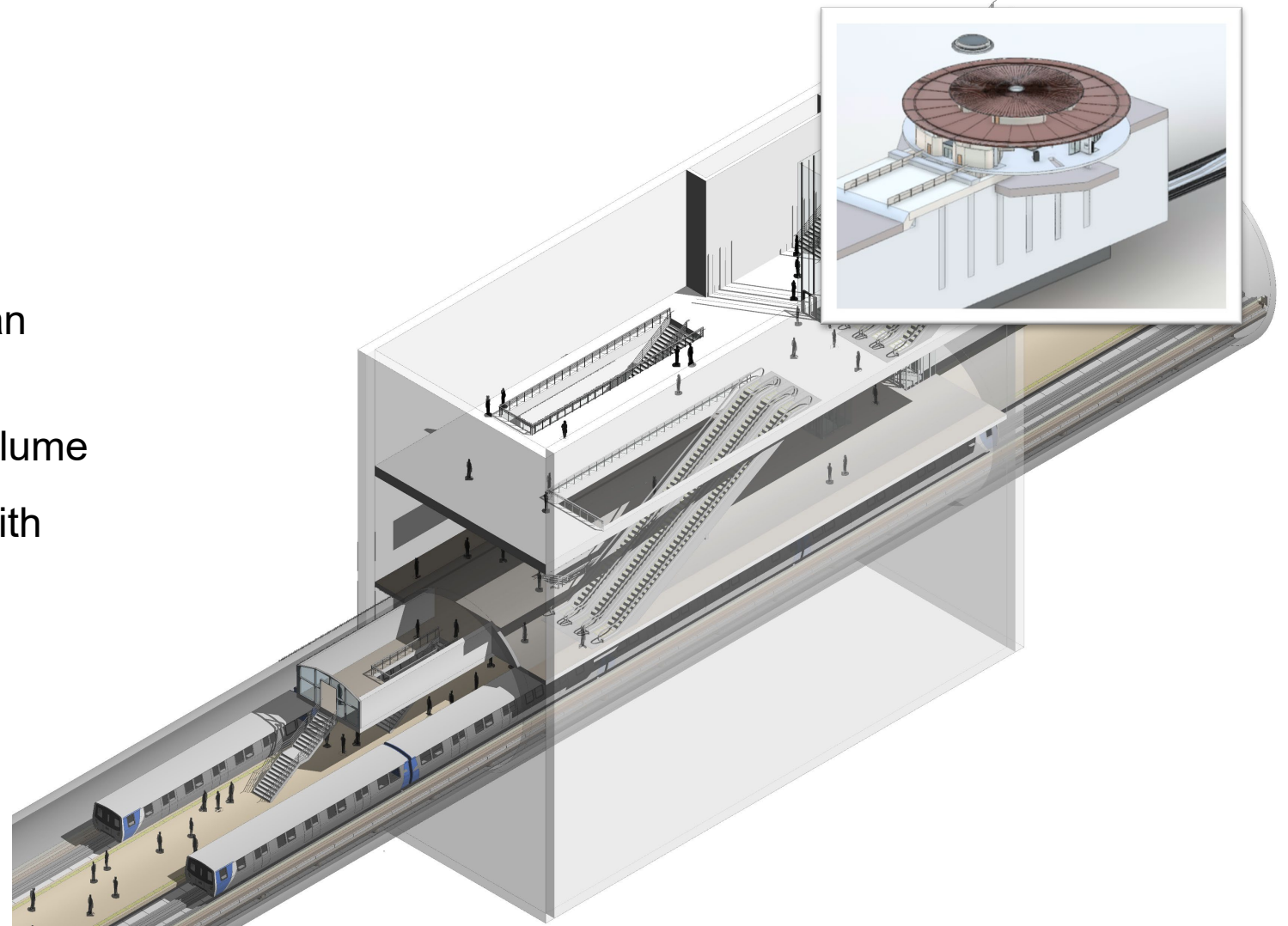

28th Street/Little Portugal Station Reconfiguration Summary

CRITERIA

↑ Improved = Neutral

- ↑ Operability
 - Take advantage of similarities to DTSJ and Diridon Stations
- ↑ Maintainability
 - Enhances maintainability through consistent configuration for all three underground stations
- ↑ Safety
 - Passenger safety enhanced with standard center platform configuration similar to DTSJ and Diridon”
- ↑ Passenger Experience
 - Center platform with simplified access from headhouse
 - Simplified wayfinding
- ↑ Risk
 - Significantly reduces excavation volume and simplifies interface between CP2 and CP4
 - Smaller footprint enhances worker safety and impacts to surrounding community
- ↑ Cost
 - Reduced cost compared to Original Design open-cut approach for station construction
- ↑ Schedule
 - Reduced overall construction duration at this site

Ventilation System Optimization

Identified Challenges with Mid-Tunnel Facilities:

- Additional fans required with original design
- Real estate acquisition and business displacements
- Complicated utility relocations
- Significant cost to construct
- Impacts to neighborhoods & traveling public

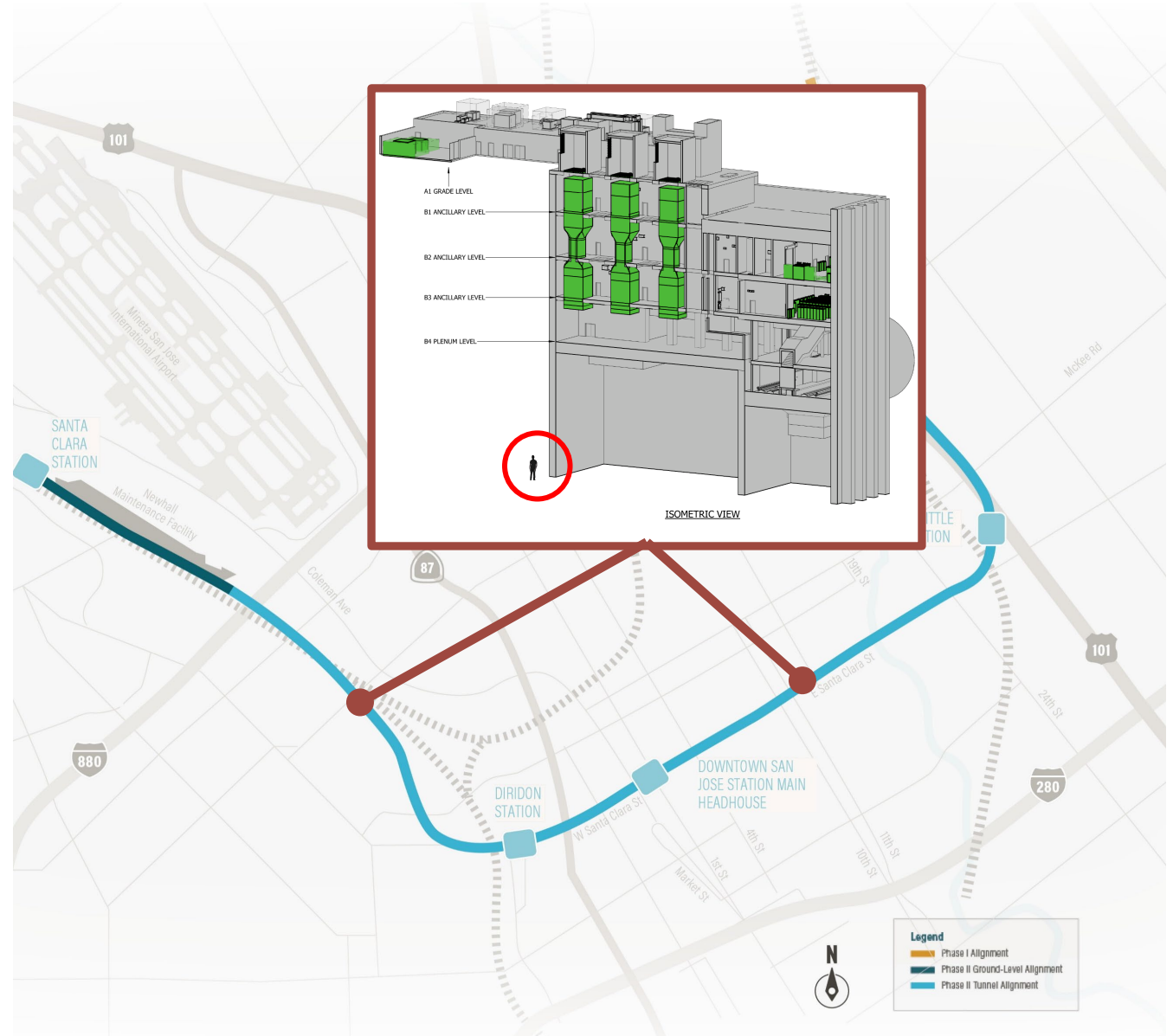

Ventilation System Optimization

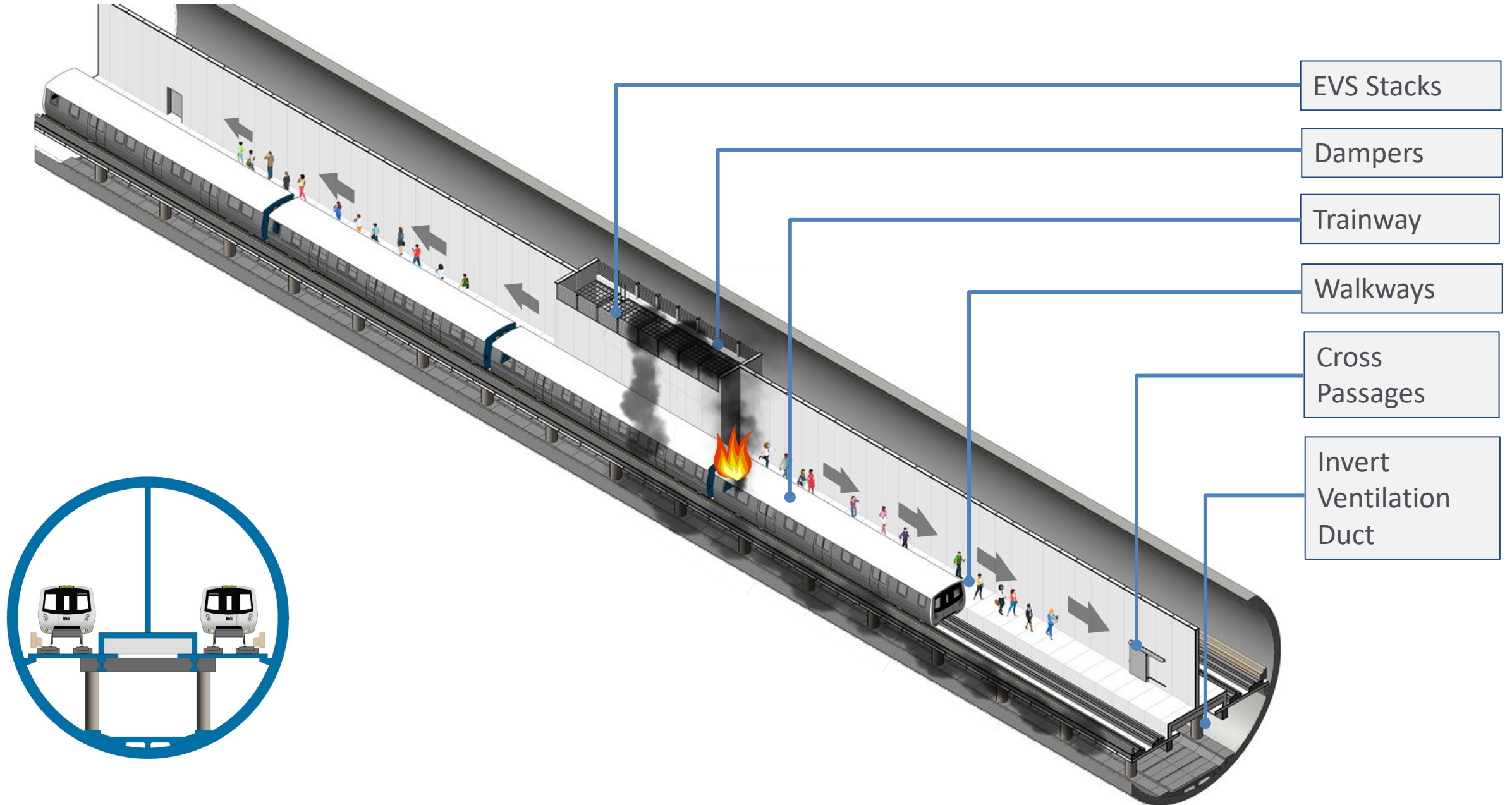

Ventilation System Optimization Summary

CRITERIA

↑ Improved = Neutral

↑	OPERABILITY	<ul style="list-style-type: none">• Consolidates operational elements to the stations
↑	MAINTAINABILITY	<ul style="list-style-type: none">• Less infrastructure to maintain, back-of-house elements are consolidated to the station locations
↑	SAFETY	<ul style="list-style-type: none">• Reduces access points to the system improving threat vulnerability• Wider emergency walkways along the length of the tunnel
=	PASSENGER EXPERIENCE	<ul style="list-style-type: none">• N/A
↑	RISK	<ul style="list-style-type: none">• Significantly reduces excavation and impacts to adjacent properties in the dense urban environment around the MTFs
↑	COST	<ul style="list-style-type: none">• Elimination of large buildings and significant excavations• Eliminated four emergency ventilation fans
↑	SCHEDULE	<ul style="list-style-type: none">• Improves schedule by reducing the amount of infrastructure needing to be constructed

Ongoing Collaboration Efforts

BART Operations Control Center (OCC)

- Comprehensive Agreement between VTA and BART provides that the expansion of BART's OCC is an anticipated modification made necessary by the extension to Santa Clara
- VTA and BART executed a Principles of Agreement in March 2016 for the OCC Project
- Subsequently, BART pursued environmental review, preliminary engineering, and preliminary design up to a 65% design level for the OCC Project, with VTA contributing \$2 million to these efforts
 - This revealed that such a project would have substantially higher cost, longer schedule and additional construction risk.
- BART determined that the best option for meeting the future operational requirements would be to modernize and retrofit BART's existing facility ("OCC Retrofit")
- BART and VTA are currently finalizing revised Principles of Agreement

Modernized OCC Overview



TRAINING ROOM



BREAK ROOM

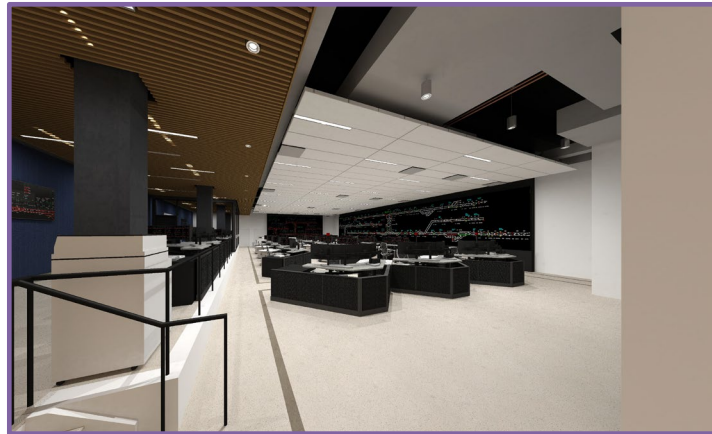

MAIN FLOOR

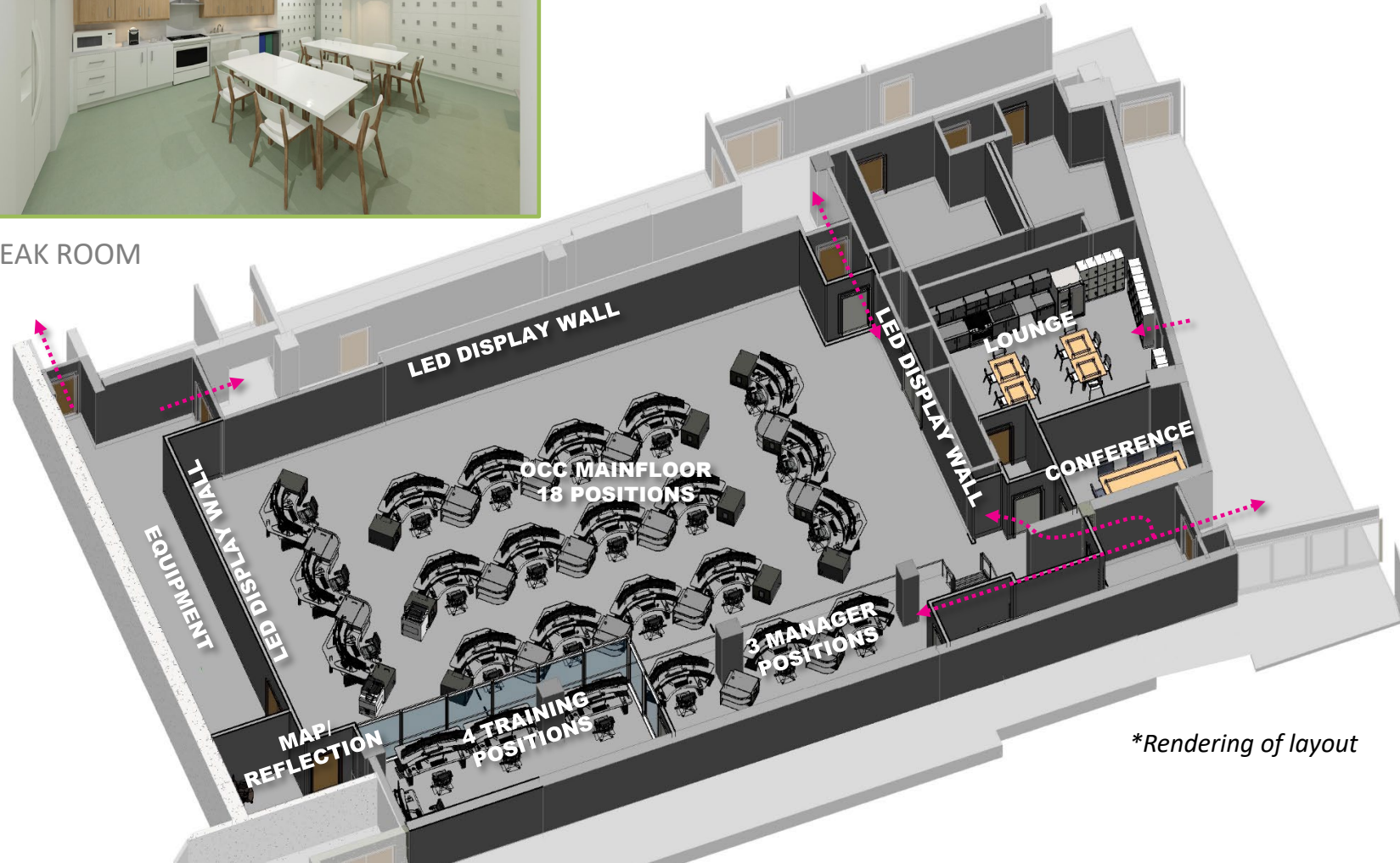

**Rendering of layout*

Peer Review/Exchange Effort

- VTA, in partnership with the American Public Transportation Association (APTA), commissioned an independent review (Peer Review/Exchange) to support the ongoing project delivery efforts of the BART Phase II Project
- APTA is conducting this effort and has assembled a peer review team with expertise in tunneling, station architecture and project management
- These independent subject matter experts are reviewing existing documentation, engineering records and conduct technical sessions considering:
 - review of the single-bore and twin-bore tunneling methodology
 - customer access and customer service with the current underground station design

Peer Review/Exchange Outcomes

- Key questions being answered:
 - Will proposed innovations to tunnel and station refinement work improve customer access, experience?
 - Identify issues which pose the greatest risk to budget and schedule
 - How to best mitigate said risks
- Peer Review findings to be discussed at VTA's September 16th Board Workshop
- Recommendations from Peer Review to be evaluated and considered for incorporation into project design and delivery

BART Silicon Valley Phase II: Recent and Upcoming Coordination

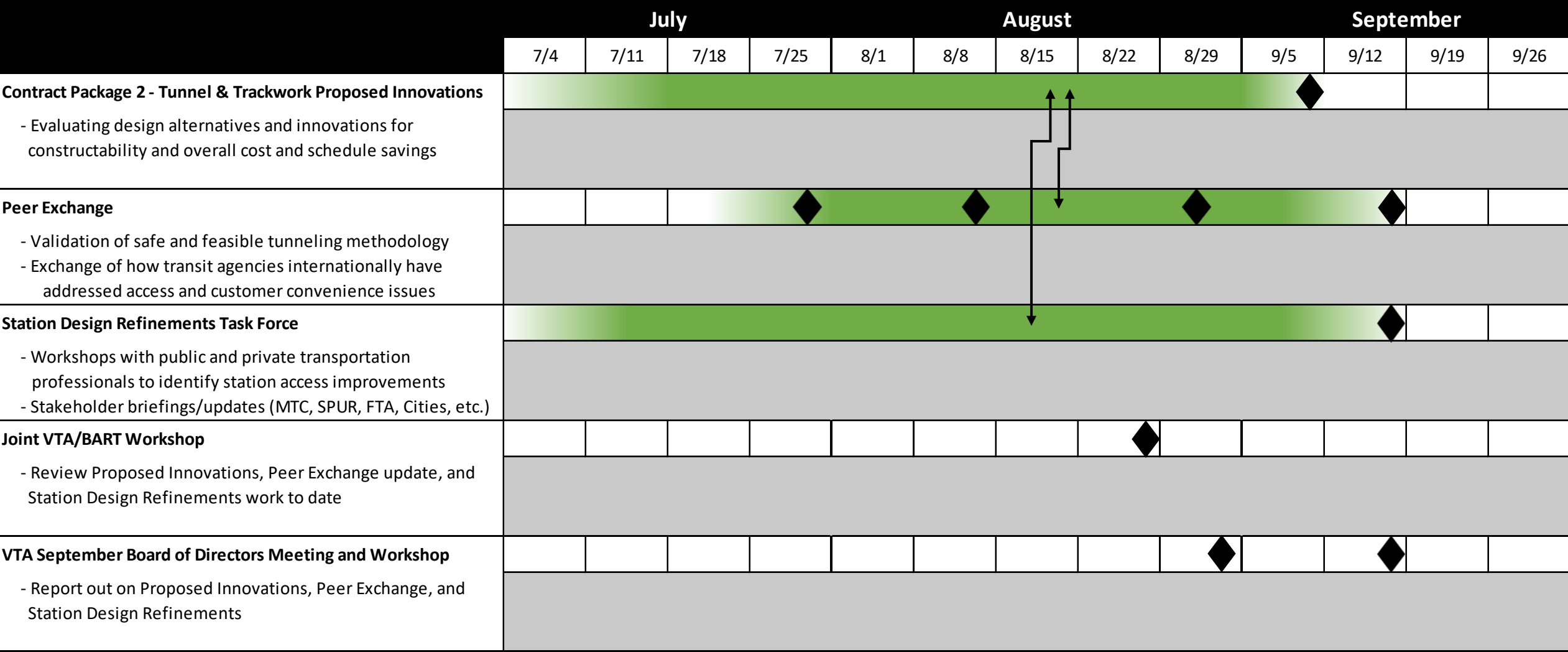

Ongoing Activities

Key Meeting/Completion of Effort

Input to effort

Future Anticipated CP2 VTA Board Updates/Actions

Anticipated VTA Board Updates/Actions for Tunnel/Track Contract (CP2)	2022				2023				2024			
	Q1	Q2	Q3	Q4	Q1	Q2	Q3	Q4	Q1	Q2	Q3	Q4
Ongoing Updates												
Awarded Stage 1 Services <i>(Innovations, programming services, engineering design, construction planning, etc.)</i>		◆										
Innovations Overview			◆									
Early Work Package #1 <i>(TBM order, utility relocations, building demolitions, site prep and portal)</i>												
Early Work Package #2 <i>(Enabling works, site prep and concrete structures)</i>												
Stage 2 <i>(Heavy Construction)</i>												

**anticipated schedule dependent on peer review and station refinement outcomes*

Questions?